

## Solid State Relays - Panel Mount: SSC



### Features

IGBT based Solid State DC Contactor • 25Amp • 800 and 1000 VDC models - DC Switching • 12, 24 and 36 VDC control available.

Product	INPUT SPECIFICATIONS	OUTPUT SPECIFICATIONS			
	Control Voltage Range	Load Current	Switching Voltage Type	Turn On	Load Voltage Range
<a href="#">SSC1000-25-12</a>	10-12 Volts DC	0.02-25 Amps DC	DC	N/A	0-1000 Volts DC
<a href="#">SSC1000-25-24</a>	20-24 Volts DC	0.02-25 Amps DC	DC	N/A	0-1000 Volts DC
<a href="#">SSC1000-25-36</a>	30-36 Volts DC	0.02-25 Amps DC	DC	N/A	0-1000 Volts DC
<a href="#">SSC800-25-12</a>	10-12 Volts DC	0.02-25 Amps DC	DC	N/A	0-800 Volts DC
<a href="#">SSC800-25-24</a>	20-24 Volts DC	0.02-25 Amps DC	DC	N/A	0-800 Volts DC
<a href="#">SSC800-25-36</a>	30-36 Volts DC	0.02-25 Amps DC	DC	N/A	0-800 Volts DC

- IGBT Output
- Panel Mount
- High Voltage
- Internal Overvoltage Protection Available
- Control Voltage 12Vdc, 24Vdc, 36Vdc

Series SSC solid state DC contactors feature IGBT technology for high voltage DC switching applications. All models come in Crydom's standard panel-mount package. Manufactured in Crydom's ISO 9001 Certified facility for optimum product performance and reliability.

## OUTPUT SPECIFICATIONS ①

MODEL NUMBERS	SSC800-25	SSC1000-25
Operating Voltage Range [Vdc]	0-800	0-1000
Maximum Transient Voltage [Vpk]	900 ④	1200 ⑤
Max. Load Current ③ [Adc]	25	25
Min. Load Current [mA]	20	20
Max. Surge Current, [Adc] (10msec)	75	75
Max. On-State Voltage Drop @ Rated Current [Vdc]	1.6	1.6
Thermal Resistance Junction to Case [R <sub>θJC</sub> ] C/W	0.8	0.8
Max. Off-State Leakage Current @ Rated Voltage [mA]	0.3	0.3
Max. Turn-On Time [msec]	1.5	1.5
Max. Turn-Off Time [msec]	1.5	1.5

## INPUT SPECIFICATIONS ①

	12	24	36
Nominal Control Voltage [Vdc] ⑥	12	24	36
Control Voltage Range [Vdc]	8-16	20-28	32-40
Maximum Turn-On Voltage [Vdc]	8	20	32
Minimum Turn-Off Voltage [Vdc]	1	1	1
Nominal Input Impedance [Ohm]	780	1500	2,400
Typical Input Current at Nominal Voltage [mA]	15	15	15

## GENERAL NOTES

- ① All parameters at 25°C unless otherwise specified.
- ② Dielectric strength and insulation resistance are measured between input and output.
- ③ Heat sinking required, for derating curves see page 2.
- ④ Internal overvoltage protection included.
- ⑤ Internal overvoltage protection not included.
- ⑥ Use suffix -12, -24 or -36 to specify control voltage. For other values call factory  
Sample: **SSC800-25-24**.

© 2007 CRYDOM Inc., Specifications subject to change without notice.

## GENERAL SPECIFICATIONS

Dielectric Strength	60Hz	2500 Vrms
Insulation Resistance (Min.) @ 500 Vdc		$10^9$ Ohm
Max. Capacitance Input/Output		50 pF
Ambient Operating Temperature Range		-30 to 80°C
Ambient Storage Temperature Range		-40 to 125°C

## MECHANICAL SPECIFICATIONS

Weight: (typical)	3.0 oz. (86.5g)
Encapsulation:	Thermally Conductive Epoxy
Terminals:	Screws and Saddle Clamps Furnished, Unmounted

## MECHANICAL SPECIFICATIONS

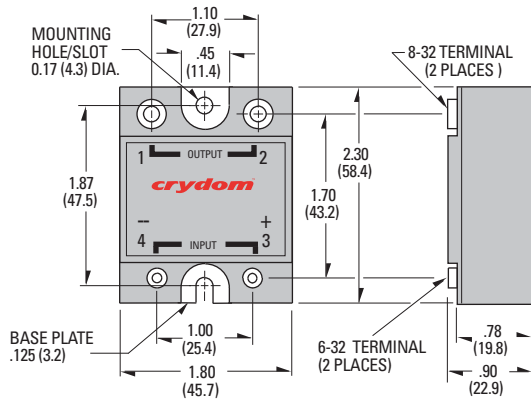

**Screw Torque Requirements:** 6-32 Screws - 10 in. lbs., 8-32 - 20in. lbs. (Screws dry without grease.)

## WIRING CONNECTIONS

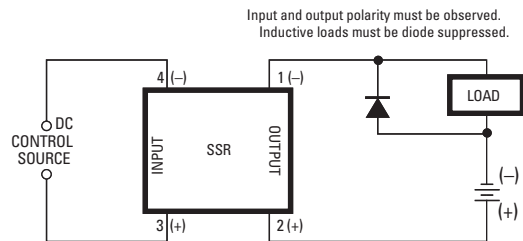

## Transient Protection

All loads are inductive, even ones that are not so labeled. An inductive load will produce harmful transient voltages when it is turned off. The more perfect the switch, the larger the transient voltages; the IGBT output is so nearly an ideal switch that the transient voltages produced by seemingly "non-inductive" loads can cause damage if not suppressed. Diodes should be fast recovery type with PIV rated greater than supply voltage.

## CURRENT DERATING CURVE

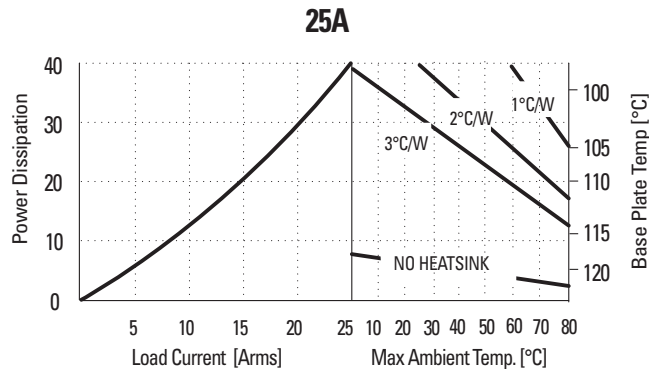

© 2007 CRYDOM Inc., Specifications subject to change without notice.